

TOLERANCE: (UNLESS NOTED) 3 PLACE DECIMAL = ±0.050 2 PLACE DECIMAL = ±0.050 1 PLACE DECIMAL = ±0.050 ALL DIMENSIONS IN INCHES. DRAWING NOT TO SCALE.		WARNING! CONFIDENTIAL INFORMATION -- PROPERTY OF ACI. UNAUTHORIZED USE STRICTLY FORBIDDEN.		 ITEM NUMBER MLP-XX-XX	
DATE 8/30/13	DESCRIPTION MINI LP ASSEMBLY	DRAWN BY TEQ	APPROVED BY TJD		

ITEM NO.	MACOLA P/N	DESCRIPTION	QTY
1	LP MINI ENC	HOUSING, MINI LP BOX, MACHINED	1
2	P-LP SM MINI	ASSEMBLY, MINI LP SENSOR, SM	1
3	0-XX" MLV LP	SENSOR, LP, 0-XX", MLV SERIES	1
4	3 POS DEPLUG HZ	CONNECTOR PLUG, SCREW TERMINALS, 3POS, 5.00MM	1
5	LP LABEL INSIDE	LABEL, LP INSIDE	1
6	LP FITTING	LP FITTING, BRASS BARBED, W/NUT	2
7	1/8 MINILP TUBE	TUBING, SILICON, .063X.125,100', MINI LP (1.625" X2)	3.25"
8	#4X5/16" SCREW	SCREW, #4X5/16" SHEET METAL SCREWING DP PCB DOWN TO HOUSING	2
9	2"X1" INSIDE LB	LABEL, 2"X1" INSIDE, POLY	1
10	3" X 2" POLY LABEL	LABEL, 3"X2" WHITE, POLY	1
11	5X7 2MIL BAGS	BAG, 5"X7", POLY 2 MIL	1
12	I0000653	A/MLP INSTALLATION INSTRUCTION	1

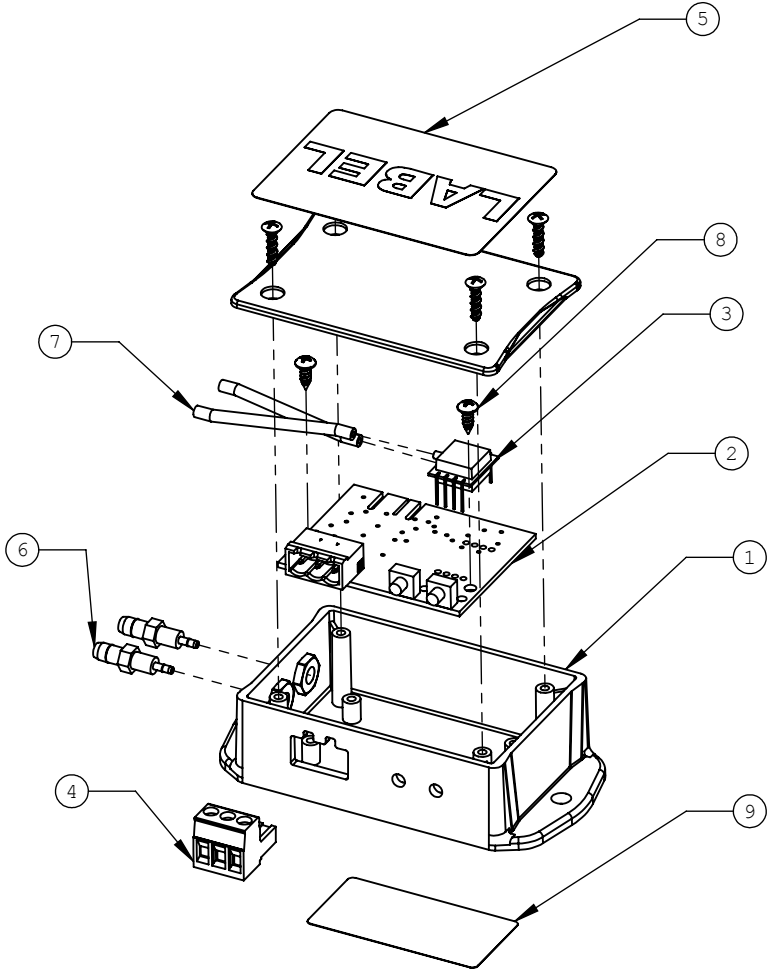

Notes:

- 1.) **PCB:** All LP Pressure Sensors use PCB# B0000051.
- 2.) **Instruction:** Must include I0000653 Installation Instructions.
- 3.) All units to be built per the 50000604 Manufacturing Process.
- 4.) All units tested per the T0000885 Test Plan.

TOLERANCE: (UNLESS NOTED)
 3 PLACE DECIMAL = ±0.050
 2 PLACE DECIMAL = ±0.050
 1 PLACE DECIMAL = ±0.050
 ALL DIMENSIONS IN INCHES.
 DRAWING NOT TO SCALE.

WARNING!
 CONFIDENTIAL
 INFORMATION -- PROPERTY
 OF ACI. UNAUTHORIZED
 USE STRICTLY FORBIDDEN.

ACI
 Automation Components, Inc.

ITEM NUMBER

MLP -XX-XX

DATE	DESCRIPTION	DRAWN BY	APPROVED BY	DRAWING NUMBER	REV
8/30/13	MINI LP ASSEMBLY	TEQ	TJD	10000227	1