



U018 Series  
(sold separately)

# E50H2A, E50H5A

Compact Power and Energy Meters  
With BACnet MS/TP Support

## Product Overview

The E50H2A and E50H5A DIN rail power meters provide a solution for measuring energy data with a single device. Inputs include control power, CT, and 3-phase voltage. Both models support BACnet MS/TP protocol. The E50H2A has one pulse contact input and a phase loss alarm output. The E50H5A has data logging capability and two pulse contact inputs. The LCD screen on the faceplate allows instant output viewing. These meters include built-in CT integrators and CT power supplies. The E50H2A and E50H5A work only with Veris U018 series rope style CTs.

The meter is housed in a plastic enclosure suitable for installation on T35 DIN rail according to EN50022. It can be mounted with any orientation over the entire ambient temperature range, either on a DIN rail or in a panel. The meters are not sensitive to CT orientation, reducing installation errors.

## Product Identification

Model	BACnet MS/TP Protocol Output	Alarm Output	Full Data Set	Data Logging	Pulse Input
E50H2	•	•	•		•
E50H5	•		•	•	• (2 pulses)

## Specifications

MEASUREMENT ACCURACY	
<b>Real Power and Energy</b>	IEC 62053-22 Class 0.5S, ANSI C12.20 0.5%
<b>Reactive Power and Energy</b>	IEC 62053-23 Class 2, 2%
<b>Current</b>	0.4% (+0.015% per °C deviation from 25°C) from 5% to 100% of range; 0.8% (+0.015% per °C deviation from 25°C) from 1% to 5% of range
<b>Voltage</b>	0.4% (+0.015% per °C deviation from 25°C) from 90V <sub>LN</sub> to 600V <sub>AC,LL</sub>
<b>Sample Rate</b>	2520 samples per second
<b>Data Update Rate</b>	1 sec
<b>Type of Measurement</b>	True RMS up to the 21st harmonic 60 Hz; One to three phase AC system
INPUT VOLTAGE CHARACTERISTICS	
<b>Measured AC Voltage</b>	Minimum 90V <sub>LN</sub> (156V <sub>LL</sub> ) for stated accuracy; UL Maximums: 600V <sub>LL</sub> (347V <sub>LN</sub> ); CE Maximum: 300V <sub>LN</sub>
<b>Metering Over-Range</b>	+20%
<b>Impedance</b>	2.5 MΩ <sub>LN</sub> /5 MΩ <sub>LL</sub>
<b>Frequency Range</b>	45 to 65 Hz
INPUT CURRENT CHARACTERISTICS	
<b>CT Scaling</b>	20A to 5000A
<b>Measurement Input Range</b>	U018 series rope style CTs only (CTs must be rated for connection to Class 1 voltage inputs)



### ⚠️ DANGER

#### HAZARD OF ELECTRIC SHOCK, EXPLOSION, OR ARC FLASH

- Follow safe electrical work practices. See NFPA 70E in the USA, or applicable local codes.
  - This equipment must only be installed and serviced by qualified electrical personnel.
  - Read, understand and follow the instructions before installing this product.
  - Turn off all power supplying equipment before working on or inside the equipment.
  - Any covers that may be displaced during the installation must be reinstalled before powering the unit.
  - Use a properly rated voltage sensing device to confirm power is off.
- DO NOT DEPEND ON THIS PRODUCT FOR VOLTAGE INDICATION**

Failure to follow these instructions will result in death or serious injury.

A qualified person is one who has skills and knowledge related to the construction and operation of this electrical equipment and the installation, and has received safety training to recognize and avoid the hazards involved. NEC2009 Article 100  
No responsibility is assumed by Veris Industries for any consequences arising out of the use of this material.

Control system design must consider the potential failure modes of control paths and, for certain critical control functions, provide a means to achieve a safe state during and after a path failure. Examples of critical control functions are emergency stop and over-travel stop.

### ⚠️ WARNING

#### LOSS OF CONTROL

- Assure that the system will reach a safe state during and after a control path failure.
- Separate or redundant control paths must be provided for critical control functions.
- Test the effect of transmission delays or failures of communication links.<sup>1</sup>
- Each implementation of equipment using communication links must be individually and thoroughly tested for proper operation before placing it in service.

Failure to follow these instructions may cause injury, death or equipment damage.

<sup>1</sup>For additional information about anticipated transmission delays or failures of the link, refer to NEMA ICS 1.1 (latest edition), *Safety Guidelines for the Application, Installation, and Maintenance of Solid-State Control* or its equivalent in your specific country, language, and/or location.

### NOTICE

- This product is not intended for life or safety applications.
- Do not install this product in hazardous or classified locations.
- The installer is responsible for conformance to all applicable codes.
- Mount this product inside a suitable fire and electrical enclosure.

#### FCC PART 15 INFORMATION

NOTE: This equipment has been tested by the manufacturer and found to comply with the limits for a class B digital device, pursuant to part 15 of the FCC Rules. These limits are designed to provide reasonable protection against harmful interference when the equipment is operated in a residential environment. This equipment generates, uses, and can radiate radio frequency energy and, if not installed and used in accordance with the instruction manual, may cause harmful interference to radio communications. This device complies with part 15 of the FCC Rules. Operation is subject to the following two conditions:

- This device may not cause harmful interference, and
- this device must accept any interference received, including interference that may cause undesired operation.

Modifications to this product without the express authorization of the manufacturer nullify this statement.

For use in a Pollution Degree 2 or better environment only. A Pollution Degree 2 environment must control conductive pollution and the possibility of condensation or high humidity. Consider the enclosure, the correct use of ventilation, thermal properties of the equipment, and the relationship with the environment. Installation category: CAT II or CAT III. Provide a disconnect device to disconnect the meter from the supply source. Place this device in close proximity to the equipment and within easy reach of the operator, and mark it as the disconnecting device. The disconnecting device shall meet the relevant requirements of IEC 60947-1 and IEC 60947-3 and shall be suitable for the application. In the US and Canada, disconnecting fuse holders can be used. Provide overcurrent protection and disconnecting device for supply conductors with approved current limiting devices suitable for protecting the wiring. If the equipment is used in a manner not specified by the manufacturer, the protection provided by the device may be impaired.

Specifications  
(cont.)

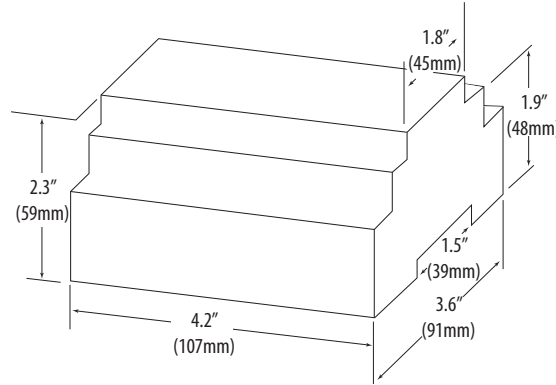
<b>CONTROL POWER</b>	
<b>AC</b>	5 VA max.; 90V min. UL Maximums: 600V <sub>LL</sub> (347V <sub>LN</sub> ); CE Maximum: 300V <sub>LN</sub>
<b>DC*</b>	3 W max.; UL and CE: 125 to 300VDC
<b>Ride Through Time</b>	100 msec at 120VAC
<b>INPUT</b>	
<b>Pulse</b>	Solid-state or mechanical contacts (current less than 1 mA); E50H2: 1 pulse input; E50H5: 2 pulse inputs)
<b>Minimum Pulse Width</b>	20 msec
<b>OUTPUT</b>	
<b>Alarm Contacts (E50H2 only)</b>	N.C., static output; (30VAC/DC, 100mA max. @25°C, derate 0.56mA per °C above 25°C)
<b>RS-485 Port</b>	2-wire, 9600 to 115.2 kbaud, BACnet MS/TP
<b>MECHANICAL CHARACTERISTICS</b>	
<b>Weight</b>	0.62 lb (0.28 kg)
<b>IP Degree of Protection (IEC 60529)</b>	IP40 front display; IP20 Meter
<b>Display Characteristics</b>	Back-lit blue LCD
<b>Terminal Block Screw Torque</b>	0.37 to 0.44 ft-lb (0.5 to 0.6 N·m)
<b>Terminal Block Wire Size</b>	26 to 14 AWG (0.13 to 2.08 mm <sup>2</sup> )
<b>Rail</b>	T35 (35mm) DIN Rail per EN50022
<b>OPERATING CONDITIONS</b>	
<b>Operating Temperature Range</b>	-30° to 70°C (22° to 158°F)
<b>Storage Temperature Range</b>	-40° to 85°C (-40° to 185°F)
<b>Humidity Range</b>	<95% RH noncondensing
<b>Altitude of Operation</b>	3000 m
<b>COMPLIANCE INFORMATION</b>	
<b>US and Canada</b>	CAT III, Pollution degree 2; for distribution systems up to 347V <sub>LN</sub> /600VAC <sub>LL</sub>
<b>CE</b>	CAT III, Pollution degree 2; for distribution systems up to 300V <sub>LN</sub>
<b>Dielectric Withstand</b>	Per UL 508, EN61010
<b>Conducted and Radiated Emissions</b>	FCC part 15 Class B, EN55011/EN61000 Class B (residential and light industrial)
<b>Conducted and Radiated Immunity</b>	EN61000 Class A (heavy industrial)
<b>US and Canada (cULus)</b>	UL508 (open type device)/CSA 22.2 No. 14-05
<b>Europe (CE)</b>	EN61010-1

\* External DC current limiting is required, see fuse recommendations.

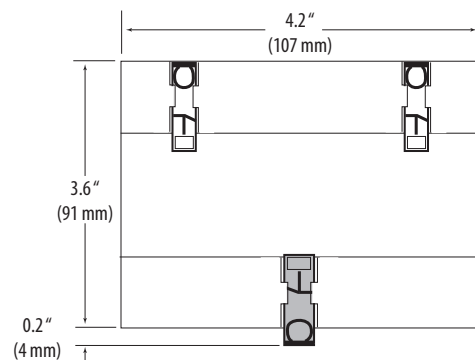
## Table of Contents

Dimensions	4
Data Outputs	4
Product Diagram	5
Display Screen Diagram	5
Installation	6
Supported System Types	7
Wiring Symbols	7
Wiring	8
Control Power Diagrams	9
Quick Setup Instructions	10
Pulse Contact Input	11
User Interface Menu Abbreviations Defined	11
User Interface for Data Configuration	12
Alert/Reset Information	13
User Interface for Setup	14
RS-485 Communications	16
BACnet Default Settings	17
BACnet Programming Information	18
Troubleshooting	28
China RoHS Compliance Information (EFUP Table)	28

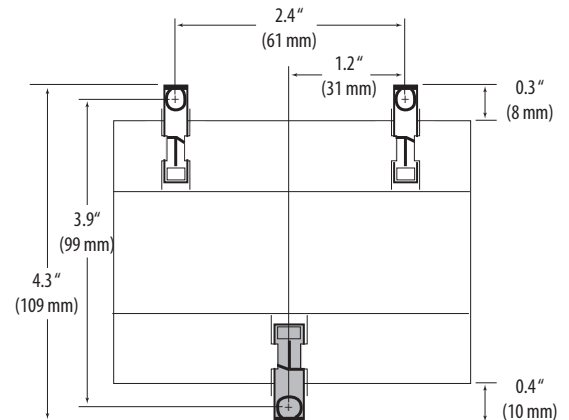
## Dimensions



*Bottom View (DIN Mount Option)*



*Bottom View (Screw Mount Option)*



## Data Outputs

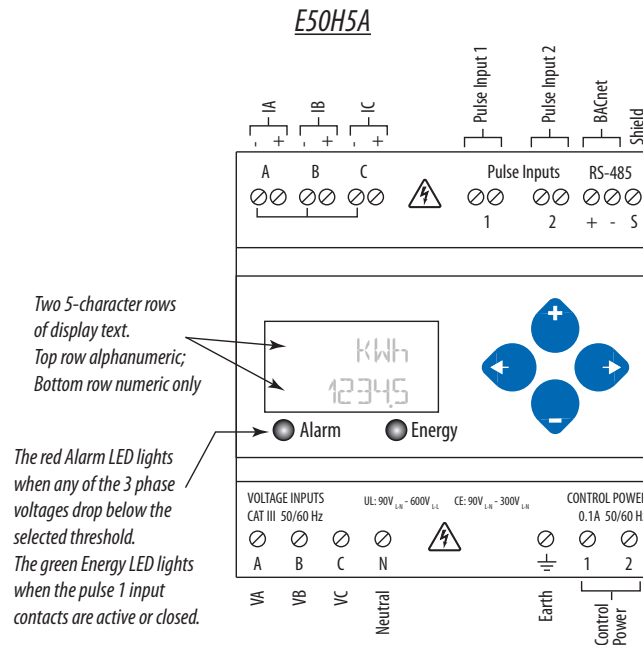
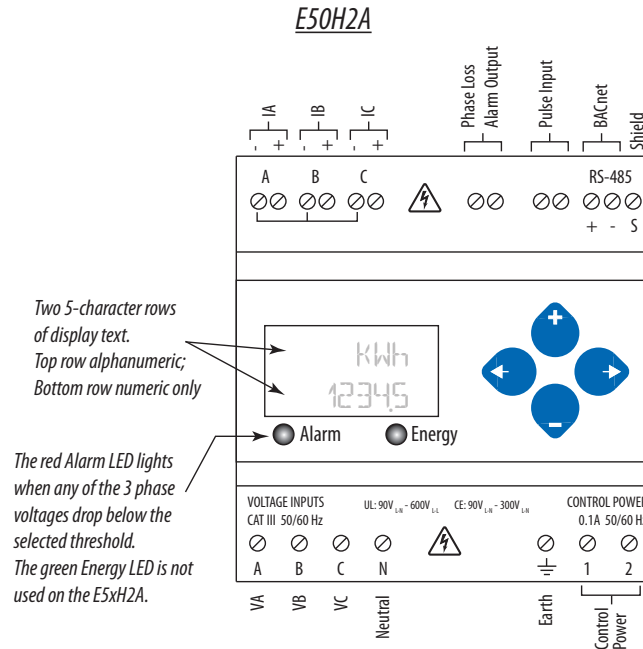
### **Full Data Set (FDS):**

- Power (kW)
- Energy (kWh)
- Configurable for CT & PT ratios, system type, and passwords
- Diagnostic alerts
- Current: 3-phase average
- Volts: 3-phase average
- Current: by phase
- Volts: by phase Line-Line and Line-Neutral
- Power: Real, Reactive, and Apparent 3-phase total and per phase
- Power Factor: 3-phase average and per phase
- Frequency
- Power Demand: Most Recent and Peak
- Demand Configuration: Fixed, Rolling Block, and External Sync
- Real Time Clock: uses BACnet Time Synchronization services

### **Data Logging (E50H5A only; includes all FDS outputs, plus):**

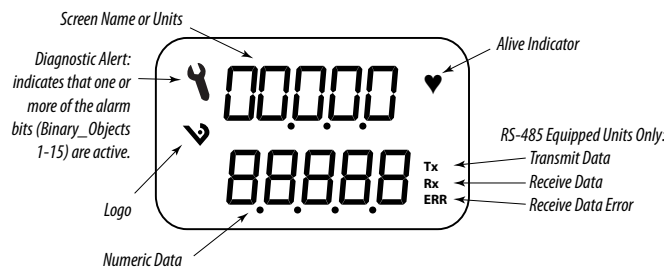
- 3 BACnet Log\_Events: each buffer holds 5760 time-stamped 32-bit entries  
(User configures which 3 data points are stored in these buffers)
- User configurable logging interval  
(When configured for a 15 minute interval, each buffer holds 60 days of data)
- Continuous and Single Shot logging modes: user selectable

## Product Diagrams

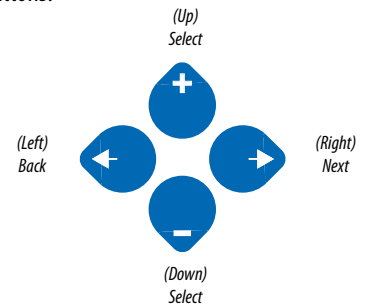


## Display Screen Diagram




### LCD Screen:



### Buttons:



## Installation

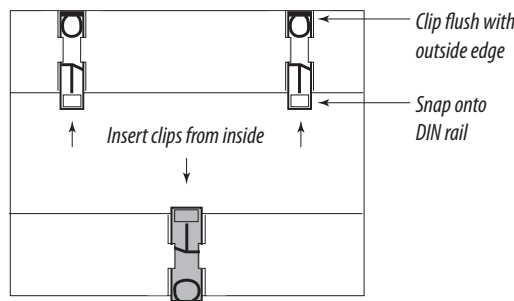
-  **Disconnect power prior to installation.**
-  **Reinstall any covers that are displaced during the installation before powering the unit.**
-  **Mount the meter in an appropriate electrical enclosure near equipment to be monitored.**

**Do not install on the load side of a Variable Frequency Drive (VFD), aka Variable Speed Drive (VSD) or Adjustable Frequency Drive (AFD).**

The meter can be mounted in two ways: on standard 35 mm DIN rail or screw-mounted to the interior surface of the enclosure.

### A. DIN Rail Mounting

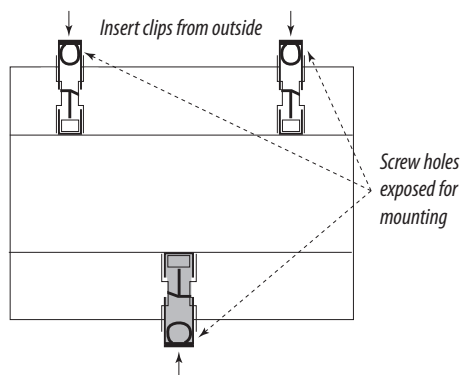
1. Attach the mounting clips to the underside of the housing by sliding them into the slots from the inside. The stopping pegs must face the housing, and the outside edge of the clip must be flush with the outside edge of the housing.
2. Snap the clips onto the DIN rail. See the diagram of the underside of the housing (below).



3. To reduce horizontal shifting across the DIN rail, use two Veris AV02 end stop clips.

### B. Screw Mounting

1. Attach the mounting clips to the underside of the housing by sliding them into the slots from the outside. The stopping pegs must face the housing, and the screw hole must be exposed on the outside of the housing.
2. Use three #8 screws (not supplied) to mount the meter to the inside of the enclosure. See the diagram of the underside of the housing (below).



## Supported System Types

The E50HxA power meters have a number of different possible system wiring configurations (see Wiring section). To configure the meter, set the System Type via the User Interface or by writing the Present\_Value of AV2 with the System Type value in the table below. The System Type tells the meter which of its current and voltage inputs are valid, which are to be ignored, and if neutral is connected. Setting the correct System Type prevents unwanted energy accumulation on unused inputs, selects the formula to calculate the Theoretical Maximum System Power, and determines which phase loss algorithm is to be used. The phase loss algorithm is configured as a percent of the Line-to-Line System Voltage (except when in System Type 10) and also calculates the expected Line to Neutral voltages for system types that have Neutral (12 & 40).

Values that are not valid in a particular System Type display as “----” on the User Interface or as QNAN in the BACnet objects.

Number of wires	CTs		Voltage Connections			System Type		Phase Loss Measurements			Wiring Diagram
	Qty	ID	Qty	ID	Type	BACnet object AV2	User Interface: SETUP>S SYS	VLL	VLN	Balance	Diagram number
Single-Phase Wiring											
2	1	A	2	A, N	L-N	10	1L + 1n		AN		1
2	1	A	2	A, B	L-L	11	2L	AB			2
3	2	A, B	3	A, B, N	L-L with N	12	2L + 1n	AB	AN, BN	AN-BN	3
Three-Phase Wiring											
3	3	A, B, C	3	A, B, C	Delta	31	3L	AB, BC, CA		AB-BC-CA	4
4	3	A, B, C	4	A, B, C, N	Grounded Wye	40	3L + 1n	AB, BC, CA	AN, BN, CN	AN-BN-CN & AB-BC-CA	5, 6

## Wiring Symbols

To avoid distortion, use parallel wires for control power and voltage inputs.

The following symbols are used in the wiring diagrams on the following pages.

Symbol	Description
	Voltage Disconnect Switch
	Fuse (installer is responsible for ensuring compliance with local requirements. No fuses are included with the meter.)
	Earth ground
	Current Transducer
	Potential Transformer
	Protection containing a voltage disconnect switch with a fuse or disconnect circuit breaker. The protection device must be rated for the available short-circuit current at the connection point.

### NOTICE

#### RISK OF EQUIPMENT DAMAGE

- This product is designed only for use with U018 series current transducers (CTs).
- DO NOT USE CURRENT OUTPUT (e.g. 5A) CTs ON THIS PRODUCT.

**Failure to follow these instructions can result in equipment damage.**

Wiring

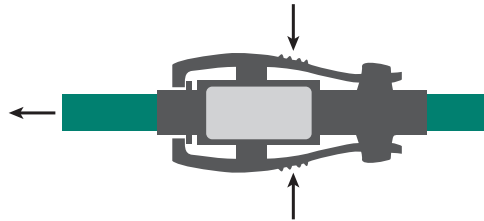
**⚠ WARNING ⚠**

**RISK OF ELECTRIC SHOCK OR PERMANENT EQUIPMENT DAMAGE**  
CT negative terminals are referenced to the meter's neutral and may be at elevated voltages

- Do not contact meter terminals while the unit is connected
- Do not connect or short other circuits to the CT terminals

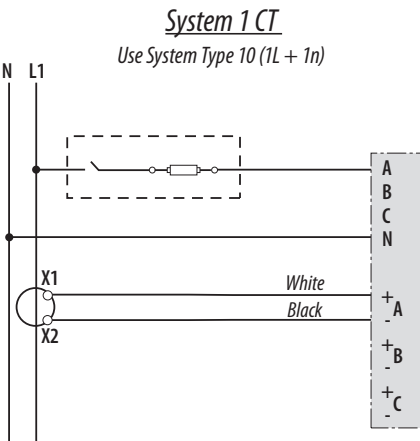
**Failure to follow these instructions may cause injury, death or equipment damage.**

1. Connect the CT output leads to the E5xxxA meter inputs according to the following diagrams. The white wire is the X1 lead.
2. Squeeze the ribbed sections of the CT connector and pull the rope out of the connector to open.

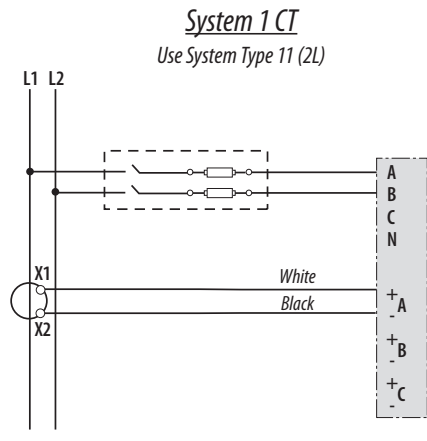


3. Wrap the rope style CT around the conductor to be monitored.
4. Snap the connector back together securely, ensuring there is no dust or debris in the closure area.

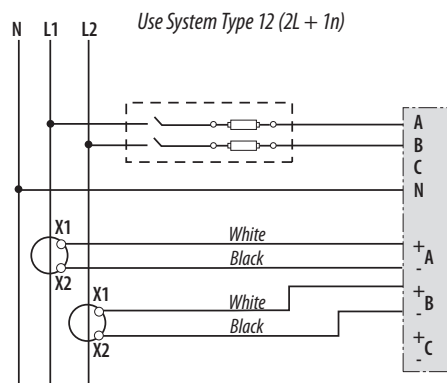
*Diagram 1: 1-Phase Line-to-Neutral 2-Wire*



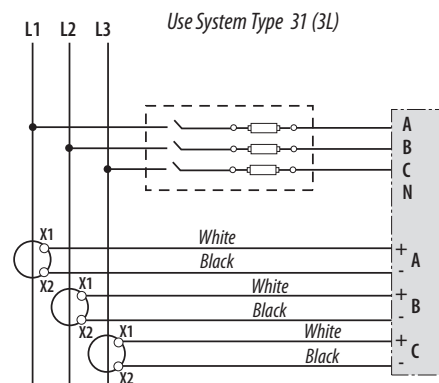
*Diagram 2: 1-Phase Line-to-Line 2-Wire*



*Diagram 3: 1-Phase Direct Voltage Connection 2 CT*



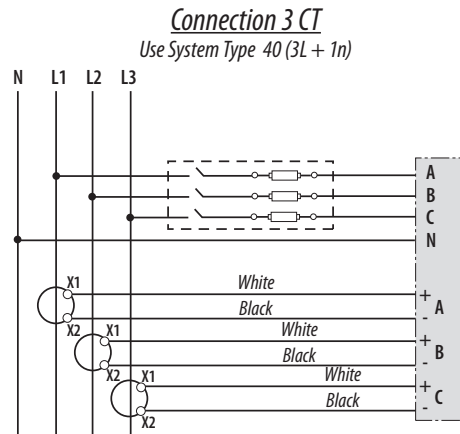
*Diagram 4: 3-Phase 3-Wire 3 CT no PT*



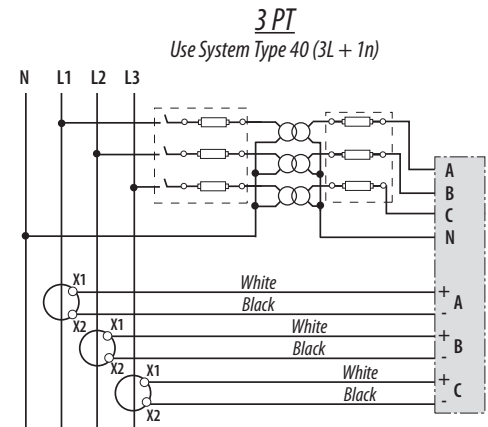


## Wiring (cont.)

**Diagram 5: 3-Phase 4-Wire Wye Direct Voltage Input**

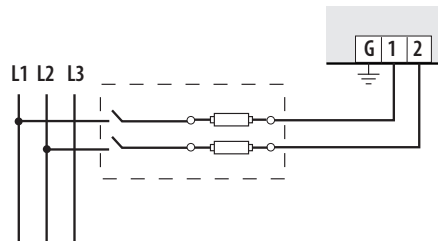


**Diagram 6: 3-Phase 4-Wire Wye Connection 3 CT**



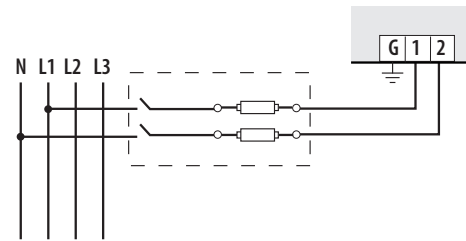
## Control Power

**Direct Connect Control Power (Line to Line)**



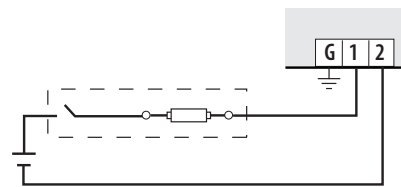
Line to Line from 90 VAC to 600 VAC (UL) (520 VAC for CE). In UL installations the lines may be floating (such as a delta). If any lines are tied to an earth (such as a corner grounded delta), see the Line to Neutral installation limits. In CE compliant installations, the lines must be neutral (earth) referenced at less than 300 VAC<sub>L-N</sub>

**Direct Connect Control Power (Line to Neutral)**



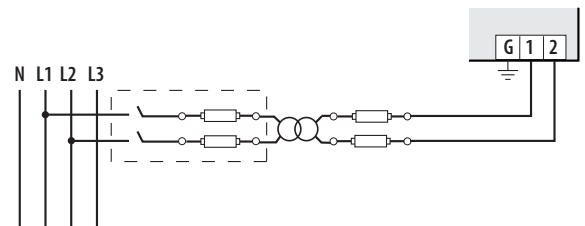
Line to Neutral from 90 VAC to 347 VAC (UL) or 300 VAC (CE)

**Direct Connect Control Power (DC Control Power)**



DC Control Power from 125 VDC to 300 VDC (UL and CE max.)

**Control Power Transformer (CPT) Connection**



The Control Power Transformer may be wired L-N or L-L. Output to meet meter input requirements

### Fuse Recommendations

Keep the fuses close to the power source (obey local and national code requirements).

For selecting fuses and circuit breakers, use the following criteria:

- Select current interrupt capacity based on the installation category and fault current capability.
- Select over-current protection with a time delay.
- Select a voltage rating sufficient for the input voltage applied.
- Provide overcurrent protection and disconnecting means to protect the wiring. For AC installations, use Veris AH02, AH03, AH04, or equivalent. For DC installations, provide external circuit protection. Suggested: 0.5 A, time delay fuses.
- The earth connection is required for electromagnetic compatibility (EMC) and is not a protective earth ground.













## Quick Setup Instructions

Use this section to enter:














- BACnet communication parameters
- CT (Current Transducer) output voltage
- The service type to be monitored

These instructions assume the meter is set to factory defaults. If it has been previously configured, check all optional values.








### **A. To Navigate to the Setup screens:**

1. Press  or  repeatedly until **SETUP** screen appears.
2. Press  to get to the **PASSWD** screen.
3. Press  to move through the digits. Use the  or  buttons to enter your password (the default is 00000).
4. Press  to move to the first Setup screen (**S BAC**).
5. Use  or  to select the parameter screen you want to set.
6. After you set the parameters you want, use  or  to select the next Setup screen or  to exit the Setup screens (return to **SETUP**).





### **B. To Enter BACnet communication parameters**

1. Navigate to the **S BAC** (set BACnet) Setup screen (see section A above).
2. Press  to go to the **MAC** screen and through the address digits. Use  or  to select the BACnet MAC address (default is 004).
3. Press  to accept the value and go to the **BAUD** screen. Use  or  to select the baud rate (default is 76.8K).
4. Press  to go to the **ID1** screen and through the upper four digits of the Device Instance. Use  or  to select the ID digits. The setup screen splits the Device ID into two parts, the most significant four digits (ID1) and the least significant three digits (ID2). The E50HxA supports BACnet Device ID values from 1 to 4,193,999. Units are shipped with a factory default setting that is pseudo-randomly generated in the range from 1,000,000 to 3,097,151.
5. Press  to accept the value and go to the **ID2** screen and through the lower three digits of the Device Instance. Use  or  to select the ID digits.
6. Press  to accept the value and go back to the **S BAC** screen.

### **C. To Enter the CT (Current Transducer) output voltage and input current ranges:**

1. Press  to go to the **CT V** screen. Use  or  to select the voltage mode Current Transducer output voltage (default is 1.00).
2. Press  to go to the **CT SZ** screen and through the digits. Use  or  to select the CT size in amps (default is 100). accept the value and
3. Press  to accept the value and go back to the **S CT** screen.

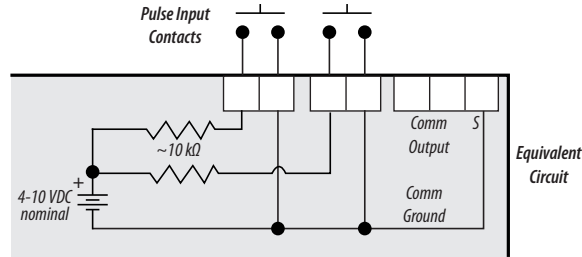
### **D. To Enter the service type to be monitored:**

1. Navigate to the **S SYS** (Set System) Setup screen (see section A above).
2. Press  to go to the **SYSTEM** screen. Use  or  to select the configuration (see wiring diagrams - default is 3LN-1N). Press  to go back to the **S SYS** screen.

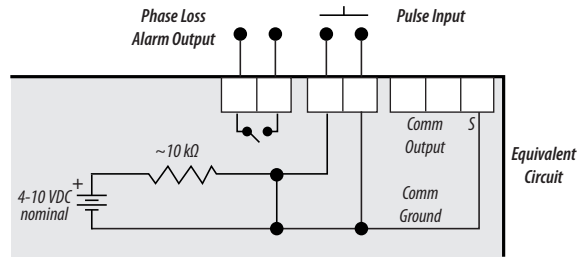
For full setup instructions, see the configuration instructions on the following pages.

## Pulse Contact Input

The E50H5A has two inputs with pulse accumulators for solid state or mechanical contacts in other sensors, such as water or gas flow meters. These inputs are isolated from the measured circuits and referenced to the communication signal ground. Use with contacts that do not require current to remove oxidation.



The E50H2A has one input with pulse accumulator as described above, and one phase loss alarm output terminal.



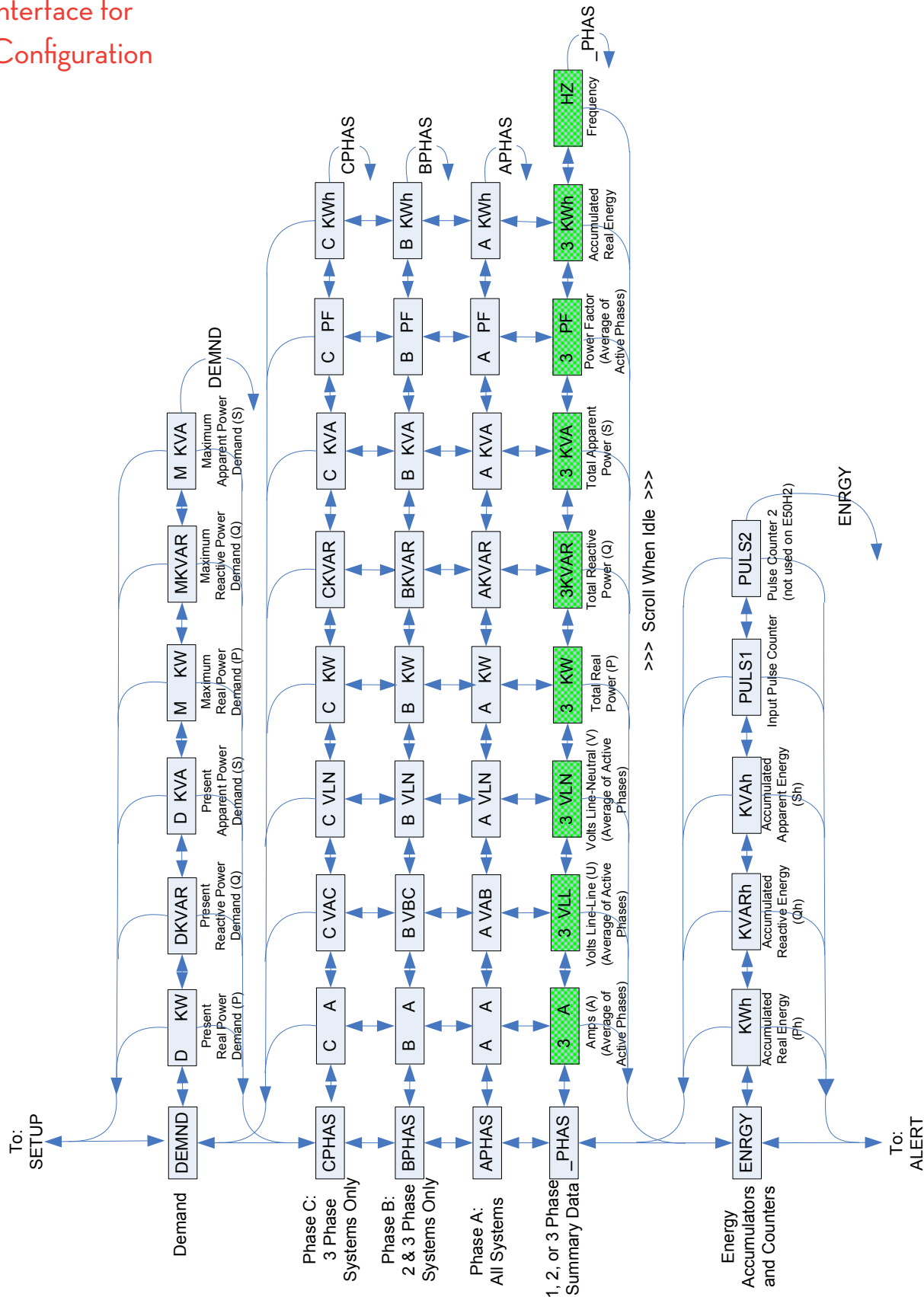
## User Interface (UI) Menu Abbreviations Defined

The user can set the display mode to either IEC or IEEE notation in the SETUP menu.

Main Menu		
IEC	IEEE	Description
D	D	Demand
MAX	M	Maximum Demand
P	W	Present Real Power
Q	VAR	Present Reactive Power
S	VA	Present Apparent Power
A	A	Amps
UAB, UBC, UAC	VAB, VBC, VAC	Voltage Line to Line
V	VLN	Voltage Line to Neutral
PF	PF	Power Factor
U	VLL	Voltage Line to Line
HZ	HZ	Frequency
KSh	KVAh	Accumulated Apparent Energy
KQh	KVARh	Accumulated Reactive Energy
KPh	KWh	Accumulated Real Energy
PLOSS	PLOSS	Phase Loss
LOWPF	LOWPF	Low Power Factor Error

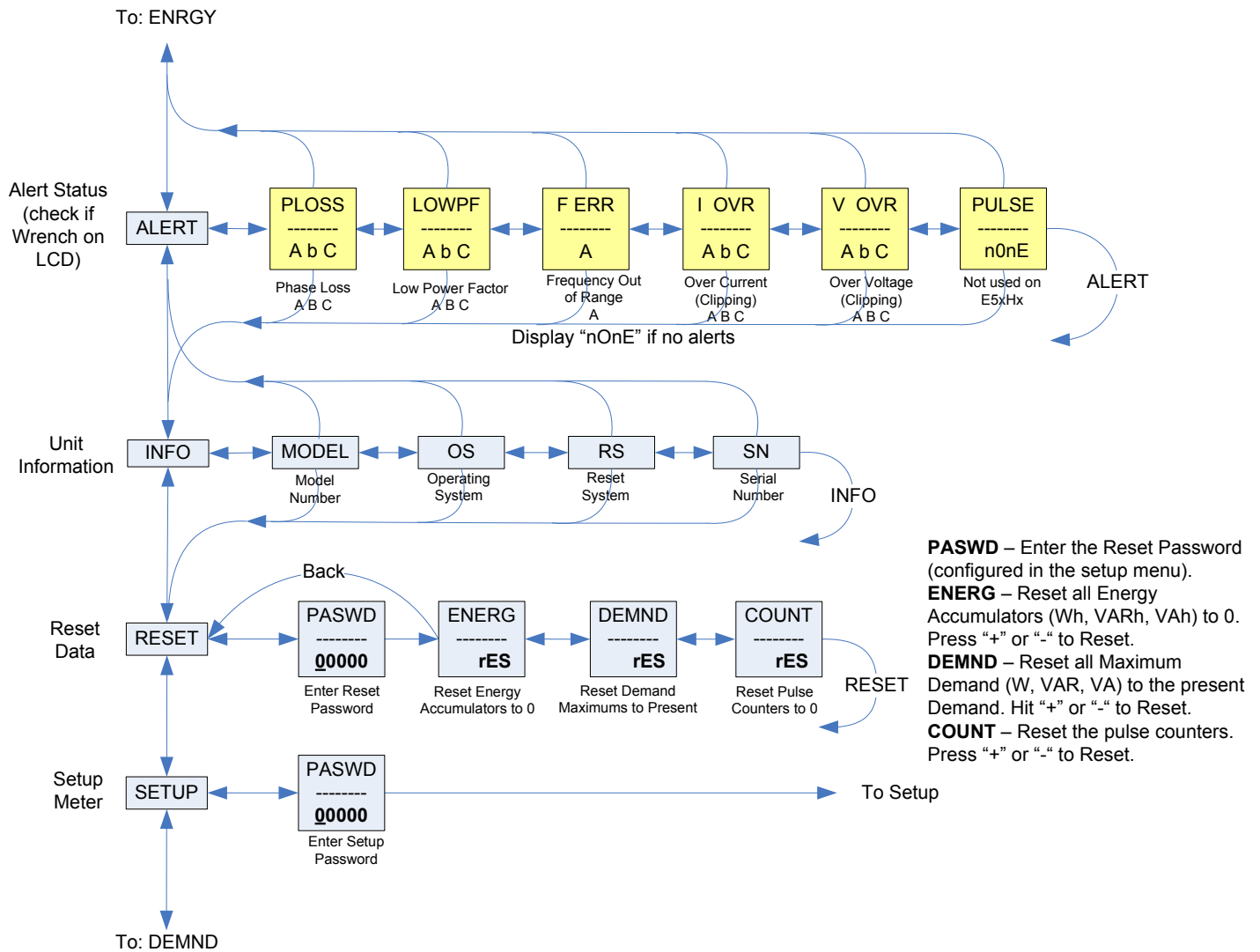
Main Menu		
IEC	IEEE	Description
FERR	FERR	Frequency Error
I OVR	I OVR	Over Current
V OVR	V OVR	Over Voltage
PULSE	PULSE	kWh Pulse Output Overrun (configuration error)
_PHASE	_PHASE	Summary Data for 1, 2, or 3 active phases
ALERT	ALERT	Diagnostic Alert Status
INFO	INFO	Unit Information
MODEL	MODEL	Model Number
OS	OS	Operating System
RS	RS	Reset System
SN	SN	Serial Number
RESET	RESET	Reset Data
PASWD	PASWD	Enter Reset or Setup Password
ENERG	ENERG	Reset Energy Accumulators
DEMND	DEMND	Reset Demand Maximums

## User Interface for Data Configuration

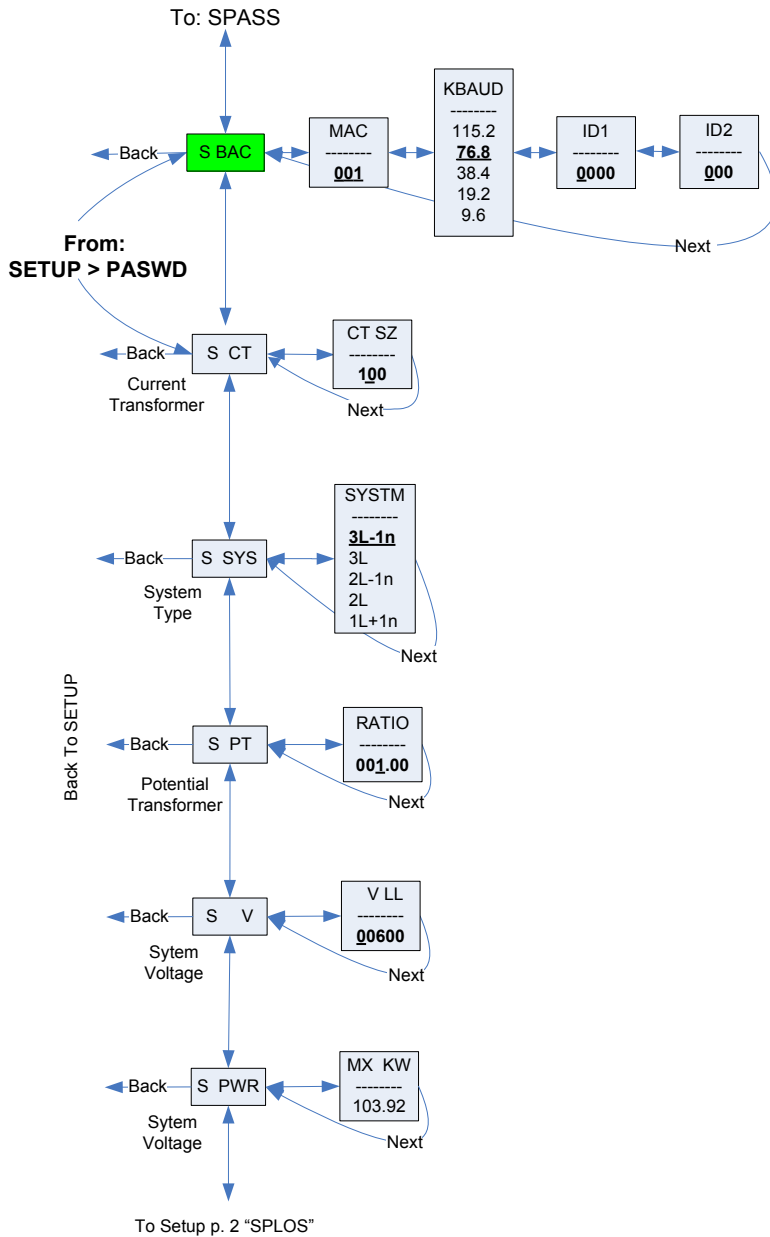


The units for all Power and Energy screens change to preserve resolution as the accumulated totals increase. For example, energy starts out as Wh, then switches to kWh, MWh, and eventually GWh as the accumulated value increases.

## Alert/Reset Information



## UI for Setup



### Set Communications Parameters:

**ADDR – BACnet MS/TP MAC Address:** 0 – 127.

+ increments the selected (blinking) digit.

– selects the digit to the left.

**BAUD - Baud Rate:** 9600 – 115200 Baud

**BACnet ID:** These two screens set the 7 digit BACnet device ID. Screen ID1 is the most significant 4 digits and ID2 the least significant three digits. This is in the range of 0 - 4,194,302.

### Set Current Transducer:

**CT SZ – CT Size:** in Amps. Maximum is 32000 Amps.

### Set System Configuration:

**SYSTEM:** + or – to step through the following System Type options:

System	Reg 130	CTs	Description
<b>3L-1n</b>	40	3	Wye Three Phase: A, B, & C with Neutral (Default).
3L	31	3	Delta Three Phase: A, B & C; no Neutral
2L-1n	12	2	Single Split Phase: A & B with Neutral
2L	11	1	Single Phase: A & B; no Neutral
1L-1n	10	1	Single Phase: A to Neutral

### Set Potential Transformer Ratio:

**RATIO – Potential transformer step down is RATIO:1.** Default is 1:1 (No PT installed). See Install for wiring diagrams. This value must be set before the System Voltage (if used).

### Set System Voltage:

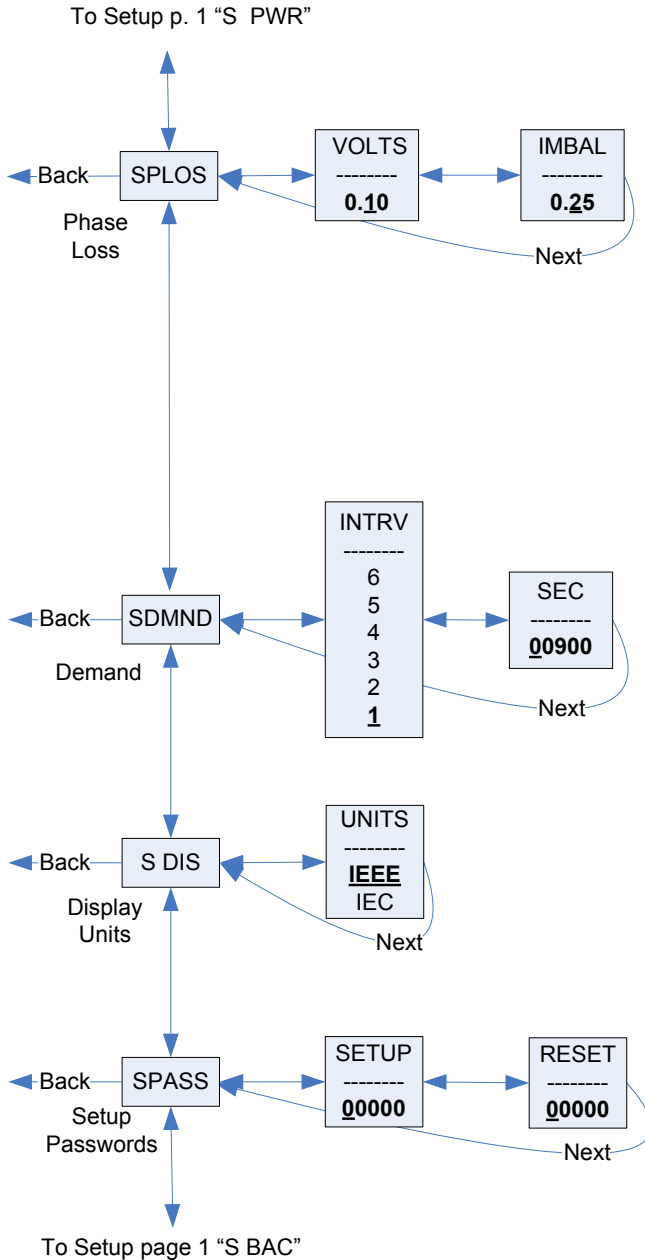
**V LL – The nominal Line to Line Voltage for the system.** This is used by the meter to calculate the theoretical maximum system power, and as the reference voltage for setting the Phase Loss threshold. Maximum is 32000 Volts. For system type 1+N (10), this is a Line to Neutral Voltage, indicated by "V LN". Note: the meter will reject settings that are not within the meter's operating range when divided by the PT ratio.

### System Power:

**MX KW – The theoretical Maximum System Power is calculated by the meter from the System Voltage, CT size, and System Type.** Power Factor is assumed to be unity. The value of System Power is used to determine which combinations of pulse weight and duration are valid and will keep up with the maximum power the meter will see. This value is read only.

Note: **Bold** is the Default.

## UI for Setup (cont.)



### Set Phase Loss:

**VOLTS - Phase Loss Voltage:** The fraction of the system voltage below which Phase Loss Alarm is on. For system types with neutral, the Line to Neutral voltage is also calculated and tested. If the System Voltage is 600 and the fraction is set to 0.10, then the Phase Loss threshold will be 60 volts.

**IMBAL - Phase Loss Imbalance:** The fractional difference in Line to Line voltages above which Phase Loss Alarm is on. For system types with neutral, the Line to Neutral voltages are also tested. For system types 1+N (10) and 2 (11), imbalance is not tested.

### Set Demand Interval:

**INTRV** - The number of Sub-Intervals (1 to 6) in a Demand Interval. Default is 1 (block demand).

**SEC** - Sub-Interval length in seconds. Default is 900 (15 minutes). Set to 0 for external sync-to-comms.

### Set Display Units: +/- to switch between:

**IEEE** - VLL VLN W VAR VA Units.

**IEC** - U V P Q S Units.

### Set Passwords:

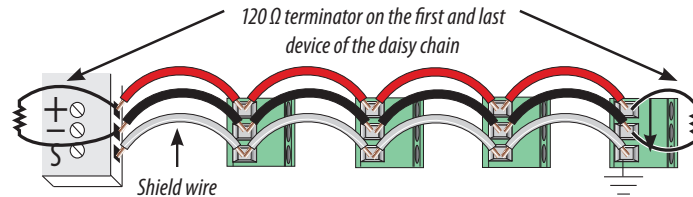
**SETUP** - The Password to enter the SETUP menu.

**RESET** - The Password to enter the RESET menu.

## RS-485 Communications

### Daisy-chaining Devices to the Power Meter

The RS-485 slave port allows the power meter to be connected in a daisy chain with up to 63 2-wire devices.

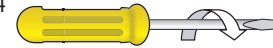


### Notes

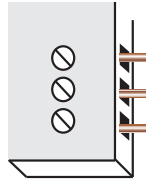
- The terminal's voltage and current ratings are compliant with the requirements of the EIA RS-485 communications standard.
- The RS-485 transceivers are  $\frac{1}{4}$  unit load or less.
- RS-485+ has a 47 k $\Omega$  pull up to +5V, and RS-485- has a 47 k $\Omega$  pull down to Shield (RS-485 signal ground).
- Wire the RS-485 bus as a daisy chain from device to device, without any stubs. Use 120  $\Omega$  termination resistors at each end of the bus (not included).
- Shield is not internally connected to Earth Ground.
- Connect Shield to Earth Ground somewhere on the RS-485 bus.

### For all terminals:

- When tightening terminals, apply the correct torque: 0.37 to 0.44 ft-lb (0.5-0.6 N-m).
- Use 14-24 gauge (2.1-0.2 mm<sup>2</sup>) wire.



0.37-0.44 ft-lb  
(0.5-0.6 N-m)





## BACnet Default Settings

Setting	Default Value*	BACnet Object
Setup Password	00000	n/a
Reset Password	00000	n/a
System Type	40 (3 + N) Wye	AV2
CT Primary Ratio	100A	AV3
CT Secondary Ratio	1V	AV4
PT Ratio	1:1 (none)	AV5
System Voltage	600 V L-L	AV6
Max. Theoretical Power	Calculated from AV2, AV3, AV5 & AV6 (with all default settings, this would be 103.92 kW)	AI45
Display Mode	1 (IEEE Units)	AV7
Phase Loss Voltage Threshold	10% of System Voltage	AV8
Phase Loss Voltage Threshold	25% Phase to Phase Imbalance	AV9
Demand: number of subintervals per interval	1 (block mode)	AV10
Demand: sub-interval length	900 sec (15 min) (AV11 default value is 90000 [1/100 seconds])	AV11
BACnet MAC Address	001	n/a
BACnet MS/TP Baud Rate	76.8 kBaud	n/a
BACnet MS/TP Max_Master	127	Device
BACnet Device_ID	Pseudo-random value from 1,000,000 to 3,097,151	Device
BACnet Device Location	Installed location not yet identified	Device
Trend_Log Object 1 Log_Device_Object_Property**	AI1 (Real Energy)	TL1
Trend_Log Object 2 Log_Device_Object_Property**	AI27 (Reactive Energy)	TL2
Trend_Log Object 3 Log_Device_Object_Property**	AI34 (Total Real Present Demand)	TL3

\* Default values are preset at the factory. Once changed, there is no way to automatically reset defaults. They must be restored individually. The baud rate and MAC address are set through the user-interface screens, and the others are set by re-writing each Object (see BACnet Programming Information section, next page).

\*\* These values are available only on the E50H5. The E50H2 does not support the data logging functions.

## BACnet Programming Information

The E50HxA is programmable via BACnet protocol and can easily be connected to a BACnet MS/TP network using an off-the shelf BACnet router. It uses five types of BACnet objects. A standard PICS (below) describes the required characteristics of the BACnet implementation, but this additional descriptive context may be helpful to the integrator.

In addition to the required properties, the device object utilizes some optional properties to support other functionality, Time Synchronization (primarily used for data/trend logging on the device) and Description and Location properties to simplify installation and maintenance. Configure all of the meter's functions, other than data logging and writable Device Properties, by writing the Present\_Value of the 11 Analog\_Value objects. These values (except for the configuration register, AV1, which always returns zero when read) are all readable and stored in nonvolatile memory so that they are retained if power to the device is interrupted.

Data values other than log information and alerts are all accessed by reading the Present\_Value of the 52 Analog\_Input objects. Most of these values are instantaneous readings of measured service parameters. Some of them, (AI1, AI26, AI27, AI37-AI45, AI47, AI50 and AI51) represent accumulated values and are stored in nonvolatile memory as well. If power to the device is interrupted, these values are retained, but no additional information accumulates until the device completes its re-initialization.

Alerts are used to indicate conditions of potential concern to the installer or the system, such as input voltage or current on any phase that exceeds the meter's measurement range, phase voltage below the Phase Loss Threshold set by the user, or Power Factor below 0.5 on any phase. Alerts are accessible individually by reading the Present\_Value of the Binary\_Input objects or as a group by reading the Present\_Value of Analog\_Input object 52. Alerts are not latched and do not generate events to system. They indicate presence of these conditions at the time they are read, but the device does not latch and store them until they are read (if the condition changes before they are read, the alert will go away).

All Analog\_Value, Analog\_Input, and Binary\_Input objects implement the reliability property and use it to indicate that the Present\_Value properties are functional, valid and current. For complete assurance, check the Reliability property for a No\_Fault\_Detected status before reading the Present\_Value of any AV, AI or BI objects.

The E50H55 includes data logging capability, which is implemented using three Trend\_Log objects. These are described in more detail in the section on data logging.

### ***BACnet Protocol Implementation Conformance Statement (PICS)***

Date:	January 1, 2013
Vendor Name:	Veris Industries, LLC
Product Name:	E50HxA Energy Meter
Product Model Number:	E50HxA
Applications Software Version:	1
Firmware Revision:	x.xxx
BACnet Protocol Revision:	4
Product Description:	3-phase electrical energy meter

**BACnet Standardized Device Profile (Annex L):** BACnet Application Specific Controller (B-ASC)

**List all BACnet Interoperability Building Blocks Supported (Annex K):** DS-RP-B, DS-RPM-B, DS-WP-B, DM-DDB-B, DM-DOB-B, DM-DCC-B, T-VMT-I-B (E50H5 only), DM-TS-B, DM-RD-B

**Segmentation Capability:** Segmentation not supported

**BACnet  
Programming  
Information  
(cont.)**

**Standard Object Types Supported:** No dynamic Creation or Deletion supported; no proprietary properties or object types

1. Device Object:

Optional Properties Supported: Max\_Master, Max\_Info\_Frames, Description, Location, Local\_Time, Local\_Date

Writable Properties: Object\_Identifier, Object\_Name, Max\_Master, Location

Property Range Restrictions: Object\_Identifier – May only write values from 1 to 4,193,999; Location – (limited to 64 characters); Max\_Master – May only write values from 1 to 127

2. Analog\_Input Objects:

Optional Properties Supported: Description, Reliability

No Writable Properties.

3. Analog\_Value Objects:

Optional Properties Supported: Description, Reliability

Writable Properties: Only the Present\_Value is writable.

Property Range Restrictions:

AV1: May only write 30078, 21211, 21212 and 16498.

AV2: May only write 10, 11, 12, 31 and 40.

AV3: May only write values from 5 to 32000.

AV4: May only write values 1 and 3.

AV5: May only write values from 0.01 to 320.0

AV6: May only write values such that AV6/AV5 is from 82 to 660 (absolute range is 82-32000). To ensure AV6 accepts/rejects the proper values, set AV5 first.

AV7: May only write values 0 and 1.

AV8: May only write values from 1 to 99.

AV9: May only write values from 1 to 99.

AV10: May only write values from 1 to 6.

AV11: May only write the value 0 or a value from 1000 to 3276700 in multiples of 100.

The Record\_Count of the Trend\_Logs (TL1 to TL3) is reset when this object is written (E50H5 only).

4. Binary\_Input Objects:

Optional Properties Supported: Description, Reliability

No Writable Properties

5. Trend\_Log Objects (E50H5A only):

Optional Properties Supported: Description,

Writable Properties: Log\_Enable, Start\_Time, Stop\_Time, Log\_DeviceObjectProperty, Log\_Interval, Stop\_When\_Full, Record\_Count

Property Range Restrictions:

Log\_DeviceObjectProperty: May only be set to the Present\_Value of local objects AI1 through AI75 (only the Present\_Value of objects AI1 through AI75 may be logged).

Log\_Interval: May only write the value 0 or values from 1000 to 3276700 in multiples of 100.

**Data Link Layer Options:** MS/TP master (Clause 9), baud rate(s): 9600, 19200, 38400, 76800, 115200

**Device Address Binding:** Static device binding is not supported. (No client functionality is included).

**Networking Options:** None

**Character Sets Supported:** ANSI X3.4

## BACnet Programming Information (cont.)

### Legend

R/W	R=read only; R/W=read or write
NV	Value is stored in non-volatile memory. The value are still available if the meter experiences a power loss and reset.
Units	Lists the physical units that a register holds.

### Device Object

Property	R/W	NV	Value Returned	Additional information
Object_Identifier	R/W	NV	Device<n>	n is the 7 digit ID # set in the ID1 & ID2 setup screens on the meter. The BACnet Device ID is a decimal number from 1 to 4,193,999 that can be entered or viewed on the user screens or through this property. The default value set at the factory is a pseudo-random number from 1,000,000 to 3,097,151 to reduce the likelihood of conflicts if multiple units are installed using their default IDs.
Object_Type	R	NV	Device (8)	
Object_Name	R	NV	Veris E50 Series Energy Meter - S/N: <serial number>	
Vendor_Name	R	NV	Veris Industries, LLC	
Vendor_Identifier	R	NV	133	
Model_Name	R	NV	E50HxA Energy Meter	
Firmware_Revision	R	NV	<Current Revision #>	"xyyy". This is the BACnet processor firmware version in the format <xyyy>, with an implied decimal point between the first two digits (x.yyy)
Application_Software_Version	R	NV	<Current version #>	"RS= xyyy, OS=xyyy, BACnet Gateway=xyyy" The format <xyyy> has an implied decimal point between the first two digits (x.yyy)
Location	R/W	NV	<Location>	Limited to 64 Characters - Default value is "Installed location not yet identified"
Description	R	NV	Veris E50HxA DIN-Rail Energy Meter S/N: <serial number>	
Protocol_Version	R	NV	1	BACnet Protocol Version 1
Protocol_Revision	R	NV	4	BACnet Protocol Revision 4
Local_Date	R		Date	Set via BACnet Time Synchronization only - reverts to Jan 1, 2000 if control power drops
Local_Time	R		Time	Set via BACnet Time Synchronization only - reverts to 12:00:00 AM if control power drops
Segmentation_Supported	R	NV	NO_SEGMENTATION (3)	Segmentation is not supported
Max_Master	R/W	NV	1-127 (Factory Default is 127)	Highest possible MAC Address for Master nodes on the local MS/TP network
Max_Info_Frames	R	NV	1	Maximum number of information frames allowed before passing the MS/TP token
Max_APDU_Length_Accepted	R	NV	480	
APDU_Timeout	R	NV	60000	
Number_of_APDU_Retries	R	NV	0	
System_Status	R	NV	Operational (0)	
Protocol_Services_Supported	R	NV	0b000000000000101101000000000000 011110000	
Protocol_Object_Types_Supported	R	NV	0b101100001000000000001000000000	

## BACnet Programming Information (cont.)

Property	R/W	NV	Value Returned	Additional information
Object_List	R	NV	DE1,AI1,AI2,AI3,AI4,AI5,AI6,AI7,AI8,AI9,AI10,AI11,AI12,AI13,AI14,AI15,AI16,AI17,AI18,AI19,AI20,AI21,AI22,AI23,AI24,AI25,AI26,AI27,AI28,AI29,AI30,AI31,AI32,AI33,AI34,AI35,AI36,AI37,AI38,AI39,AI40,AI41,AI42,AI43,AI44,AI45,AI46,AI47,AI48,AI49,AI50,AI51,AI52,AV1,AV2,AV3,AV4,AV5,AV6,AV7,AV8,AV9,AV10,AV11,BI1,BI2,BI3,BI4,BI5,BI6,BI7,BI8,BI9,BI10,BI11,BI12,BI13,BI14,BI15,TL1,TL2,TL3	BI15, TL1, TL2, and TL3 are present in the E50H5 only.
Device_Address_Binding	R	NV	{}	
Database_Revision	R	NV	0	

### Analog\_Value Objects

Use the Present\_Value property of the Analog\_Value object for all writable variables in the meter other than those used specifically for BACnet configuration, Time Synchronization (in the Device Object), or data logging (in the Trend\_Log objects).

Values are checked when written, and errors are returned for invalid entries. This table describes how the meter uses those variables, what values are valid, and what their defaults are. When writing values to the Present\_Value properties of Analog\_Value BACnet objects, there is a delay of up to about two seconds to validate and store the new value. An immediate read of the same property before that delay has elapsed can return the prior value (even if the new value was accepted). To read a value immediately after writing it, check the Reliability property first. When it reports a No\_Fault\_Detected status, the Present\_Value of the object is current.

These objects support the Description and Reliability object properties and all required Analog\_Value object properties, but Present\_Value is the only writable property.

#	Name	Description	R/W	NV	Units	Range	Factory Default Value	Additional information
AV1	Config	Configuration	R/W		n/a	n/a	Always returns "0" when read	Command Register: - Write 30078 (0x757E) to clear all energy accumulators to 0 (All). - Write 21211 (0x52DB) to begin new Demand Sub-Interval calculation cycle and log another data value on Trend_Log objects TL1-TL3 (when the meter is in Manual "Sync-to Comms" mode). This takes effect at the end of the next 1 second calculation cycle. Write no more frequently than every 10 seconds. Trend_Log values are only present on the E50H5A model. - Write 21212 (0x52DC) to reset Max Demand values to Present Demand Values. Takes effect at the end of the next 1 second calculation cycle. Write no more frequently than every 10 seconds. - Write 16498 (0x4072) to clear pulse counters to 0.
AV2	System_Type	System Type	R/W	NV	n/a	40, 31, 12, 11, 10	40	System_Type: - Write 10 for Single-Phase: A + N - Write 11 for Single-Phase: A + B - Write 12 for Split-Phase: A + B + N - Write 31 for 3-Phase Δ: A + B + C, no N - Write 40 for 3-Phase Y: A + B + C + N
AV3	CT_Ratio_Primary	CT Ratio - Primary	R/W	NV	Amps	5-5000	100	Current Transducer Size - Primary Current Range (Default is set for 100 A CTs)
AV4	CT_Ratio_Secondary	CT Ratio - Secondary	R	NV	n/a	n/a	1	Reserved
AV5	PT_Ratio	PT Ratio	R/W	NV	Value	0.01 - 320.0	1	Potential Transformer Ratio - The default is 1.00 (1:1), which is no PT attached. Set this value before setting the System Voltage (below).

## BACnet Programming Information (cont.)

#	Name	Description	R/W	NV	Units	Range	Factory Default Value	Additional information
AV6	System_Voltage	System Voltage	R/W	NV	Volts	from 82 (times the PT_Ratio in AV5) to 660 (times the PT_Ratio in AV5 - absolute limits are 82-32000)	600	System Voltage – This voltage is Line to Line unless in System Type 10 (in object AV2), in which case it is Line to Neutral. This value is used to by the meter to calculate the full scale power for the analog outputs and pulse configuration (see below), and as full scale for phase loss (in object AV8). Do not set the meter to voltages outside the range of 82-660 volts times the PT Ratio in object AV5.
AV7	Display_Units	Display Units	R/W	NV	n/a	0,1	1	Display Units: 0 = IEC (U, V, P, Q, S), 1 = IEEE (default: VLL, VLN, W, VAR, VA)
AV8	Phase_Loss_Voltage_Threshold	Phase Loss Voltage Threshold	R/W	NV	Percent	1-99	10	Phase Loss Voltage Threshold in percent of System Voltage (in object AV6). Default is 10 (10%). Any phase (as configured in AV2) whose level drops below this threshold triggers a Phase Loss alert - i.e. if the System voltage is set to 480 V L-L, the L-N voltage for each phase should be 277 V. When the threshold is set to 10%, if any phase drops more than 10% below 277 V, (less than 249 V), or if any L-L voltage drops more than 10% below 480 V (less than 432 V) the corresponding phase loss alarm bit will be true.
AV9	Phase_Loss_Imbalance_Threshold	Phase Loss Imbalance Threshold	R/W	NV	Percent	1-99	25	Phase Loss Imbalance Threshold in Percent. Default is 25% phase to phase difference. For a 3-phase Y (3 + N) system type (40 in object AV2), both Line to Neutral and Line to Line voltages are tested. In a 3-phase Δ System type (31 in object AV2), only Line to Line voltages are examined. In a single split-phase (2 + N) system type (12 in object AV2), only the line to neutral voltage are compared.
AV10	Subintervals	Number Subintervals Per Demand Interval	R/W	NV		1-6	1	Number of Sub-Intervals per Demand Interval. Sets the number of sub-intervals that make a single demand interval. For block demand, set this to 1. Default is 1. When Sub-Interval Length (in object AV11) is set to 0 (sync-to-comms mode), the meter ignores this value.
AV11	Subinterval_Length	Subinterval Length	R/W	NV	hundredths of a second	0, 10-32767	90000	Sub-Interval Length in hundredths of a second. For sync-to-comms mode, which allows manual triggering of demand intervals and the logging of another Trend_Log record, set this value to 0 and write 21211 to the reset register (object AV1) each time the sub-interval must be externally reset. Default is 90000 (15 minutes). This variable is tied directly to the Log_Interval property of all three Trend_Log objects (their value is always the same as this one). Changing any of these four properties changes all of them. Trend_Log values are only used on the E50H5A model.

## BACnet Programming Information (cont.)

### Analog\_Input Objects

Use the Present\_Value property of the Analog\_Input objects for all read-only numeric variables in the meter other than those used specifically for device configuration (in the Device Object) or data logging (in the Trend\_Log objects). Only the E50H5A supports the data logging capability.

These objects support the Description and Reliability object properties and all required Analog\_Input object properties. None of them are writable. The values that are not instantaneous (i.e., Accumulated Energy, Max Demand, Pulse Input Counts) are non-volatile. They are not updated while control power is inactive, but their past values are retained when power is restored. The Present\_Value of the accumulated data objects (AI1, AI26-AI27 and AI42-AI44) use floating-point data types (all AI objects use floating point data points). The resolution of the accumulated values decreases as the value grows larger over time and more of the significant digits precede the decimal point. If the size of the value limits the resolution unacceptably, read and store the current value offline and reset the accumulators to restore finer resolution.

For complete assurance, check the Reliability property for a No\_Fault\_Detected status before reading the Present\_Value. If the line voltage or input frequency of the system being monitored falls out of the supported range, the corresponding alert bits (BI1-BI7) are set and the reliability property of any values that cannot be accurately measured under those conditions returns Unreliable\_Other.

#	Object_Name	Description	R/W	NV	Units	Range	Additional information
AI1	Energy	Real Energy Consumption	R	NV	kWh	0 - 3.4+E38	
AI2	kW_Total	Total Real Power	R		kW	0 - Max_Power (AI45)	
AI3	kVAR_Total	Total Reactive Power	R		kVAR	0 - Max_Power (AI45)	
AI4	kVA_Total	Total Apparent Power	R		kVA	0 - Max_Power (AI45)	
AI5	PF_Total	Total Power Factor	R		Power Factor	0.00 - 1.00	1.00 for 100%
AI6	Volts_LL_Avg	Voltage L-L Average	R		Volts		
AI7	Volts_LN_Avg	Voltage L-N Average	R		Volts		
AI8	Current_Avg	Current Average	R		Amps		
AI9	kW_A	Real Power Phase A	R		kW	0 - Max_Power (AI45)	
AI10	kW_B	Real Power Phase B	R		kW	0 - Max_Power (AI45)	
AI11	kW_C	Real Power Phase C	R		kW	0 - Max_Power (AI45)	
AI12	PF_A	Power Factor Phase A	R		Power Factor	0.00 - 1.00	1.00 for 100%
AI13	PF_B	Power Factor Phase B	R		Power Factor	0.00 - 1.00	1.00 for 100%
AI14	PF_C	Power Factor Phase C	R		Power Factor	0.00 - 1.00	1.00 for 100%
AI15	Volts_AB	Voltage Phase A-B	R		Volts		
AI16	Volts_BC	Voltage Phase B-C	R		Volts		
AI17	Volts_AC	Voltage Phase A-C	R		Volts		
AI18	Volts_AN	Voltage Phase A-N	R		Volts		
AI19	Volts_BN	Voltage Phase B-N	R		Volts		
AI20	Volts_CN	Voltage Phase C-N	R		Volts		
AI21	Current_A	Current Phase A	R		Amps		
AI22	Current_B	Current Phase B	R		Amps		
AI23	Current_C	Current Phase C	R		Amps		
AI24	Reserved_AI24	Reserved	R		n/a		Returns QNAN or any value
AI25	Frequency	Frequency	R		Hz	45.0-65.0	Returns QNAN if frequency is out of range (or no voltage input present on Phase A)

## BACnet Programming Information (cont.)

#	Object_Name	Description	R/W	NV	Units	Range	Additional information
AI26	kVAh	Apparent Energy Consumption	R	NV	kVAh	0 - 3.4+E38	The UNITS property of object AI26 reports that these units are kWh because there is no unit type in the BACnet standard for kVAh.
AI27	kVARh	Reactive Energy Consumption	R	NV	kVARh	0 - 3.4+E38	The UNITS property of object AI27 reports that these units are kWh because there is no unit type in the BACnet standard for kVARh.
AI28	kVA_A	Apparent Power Phase A	R		kVA	0 - Max_Power (AI45)	
AI29	kVA_B	Apparent Power Phase B	R		kVA	0 - Max_Power (AI45)	
AI30	kVA_C	Apparent Power Phase C	R		kVA	0 - Max_Power (AI45)	
AI31	KVAR_A	Reactive Power Phase A	R		kVAR	0 - Max_Power (AI45)	
AI32	KVAR_B	Reactive Power Phase B	R		kVAR	0 - Max_Power (AI45)	
AI33	KVAR_C	Reactive Power Phase C	R		kVAR	0 - Max_Power (AI45)	
AI34	KW_Present_Demand	Total Real Power Present Demand	R		kW	0 - Max_Power (AI45)	
AI35	KVAR_Present_Demand	Total Reactive Power Present Demand	R		kVAR	0 - Max_Power (AI45)	
AI36	KVA_Present_Demand	Total Apparent Power Present Demand	R		kVA	0 - Max_Power (AI45)	
AI37	KW_Max_Demand	Total Real Power Maximum Demand	R	NV	kW	0 - Max_Power (AI45)	This retains the largest value measured for Total Real Power Demand (AI34) for any single demand interval since the Max Demand were last explicitly reset via AV1 (this is also reset when the demand interval is changed).
AI38	KVAR_Max_Demand	Total Reactive Power Maximum Demand	R	NV	kVAR	0 - Max_Power (AI45)	This retains the largest value measured for Total Reactive Power Demand (AI35) for any single demand interval since the Max Demand were last explicitly reset via AV1 (this is also reset when the demand interval is changed).
AI39	KVA_Max_Demand	Total Apparent Power Maximum Demand	R	NV	kVA	0 - Max_Power (AI45)	This retains the largest value measured for Total Apparent Power Demand (AI36) for any single demand interval since the Max Demand were last explicitly reset via AV1 (this is also reset when the demand interval is changed).
AI40	E50H2: Pulse Count E50H5: Pulse_Count_1	E50H2: Pulse Count E50H5: Pulse Count #1	R	NV	#	0 - 4294967040	Running count of contact closures on Pulse1 input since last reset. Write 16498 (0x4072) to the Present_Value property of Analog_Value object AV1 to reset both Pulse Counters to 0.
AI41	E50H2: Reserved E50H5: Pulse_Count_2	E50H2: Reserved E50H5: Pulse Count #2	R	NV	#	0 - 4294967040	E50H2A: Reserved E50H5A: Pulse Count 2; Running count of contact closures on Pulse2 input since last reset. Write 16498 (0x4072) to the Present_Value property of Analog_Value object AV1 to reset both Pulse Counters to 0.
AI42	KWH_A	Real Energy Consumption Phase A	R	NV	kWh	0 - 3.4+E38	



## BACnet Programming Information (cont.)

#	Object_Name	Description	R/W	NV	Units	Range	Additional information
AI43	KWH_B	Real Energy Consumption Phase B	R	NV	kWh	0 - 3.4+E38	
AI44	KWH_C	Real Energy Consumption Phase C	R	NV	kWh	0 - 3.4+E38	
AI45	Max_Power	Theoretical Maximum System Power	R	NV	kW	0 - 1.84467e19	Theoretical Maximum System Power – This is the theoretical maximum power the meter expects to see on a service. It is calculated by the meter from the System Type (in object AV2), CT Size (in object AV3), and System Voltage (in object AV6) - Power Factor is assumed to be unity. The register is updated whenever the user changes any of these parameters.
AI46	Reserved_AI46	Reserved	R				Returns QNAN or any value
AI47	Energy Resets	Count of Energy Accumulator Resets	R	NV		0 - 32767	Running count of how many times the energy counter has been reset
AI48	Reserved_AI48	Reserved	R				Returns QNAN or any value
AI49	Reserved_AI49	Reserved	R				Returns QNAN or any value
AI50	Power Up Count	Power Up Counter	R	NV		0 - 32767	Running count of product power-up cycles (Control Power)
AI51	Ouput Config	Ouput Configuration	R	NV		0 - 15	E50H2A returns "11" E50H5A returns "10"
AI52	Alarm_Bitmap	Alarm_Bitmap	R			0 - 32767	This contains a decimal value that represents the status of all Binary_Object alert values in one number that can be read without having to access multiple objects (the E50H2A has 14 values, the E50H5A has 15). It is a decimal representation of a 14-bit or 15-bit hexadecimal value produced by combining the alert bits into one number, where the bit value of Object BI1 is the least significant bit and BI14 or BI15 is the most significant bit.

### Binary\_Input Objects

Use the Present\_Value properties of the Binary\_Input objects as alerts for conditions of potential concern regarding to the system measurement. These values are dynamic and are not latched, so if the condition is resolved, the alert goes inactive, whether it has been read or not.

These objects support the Description and Reliability object properties and all required Binary\_Input object properties. None of them are writable. For complete assurance, check the Reliabilty property for a No\_Fault\_Detected status before reading the Present\_Value.

To test the meter's alert status, read the Present\_Value of each of the Binary\_Input objects representing the alert bits of interest, or read the Present\_Value of AI52, which combines all these bits into a single decimal value. AI52 represents the status of all 14 or 15 Binary\_Object alert values in one number that can be read without having to access multiple objects. The bit value of Object BI1 is the least significant bit and BI14 or BI15 is the most significant bit (BI15 is only present on the E50H5A).

#	Name	Description	R/W	Range	Additional information
BI1	Volts_Error_A	Voltage Out of Range Phase A	R	0=INACTIVE, 1=ACTIVE	Phase A Input Voltage exceeds meter's measurement range
BI2	Volts_Error_B	Voltage Out of Range Phase B	R	0=INACTIVE, 1=ACTIVE	Phase B Input Voltage exceeds meter's measurement range
BI3	Volts_Error_C	Voltage Out of Range Phase C	R	0=INACTIVE, 1=ACTIVE	Phase C Input Voltage exceeds meter's measurement range
BI4	Current_Error_A	Current Out of Range Phase A	R	0=INACTIVE, 1=ACTIVE	Phase A Current out of range
BI5	Current_Error_B	Current Out of Range Phase B	R	0=INACTIVE, 1=ACTIVE	Phase B Current out of range
BI6	Current_Error_C	Current Out of Range Phase C	R	0=INACTIVE, 1=ACTIVE	Phase C Current out of range
BI7	Frequency_Error	Frequency Error	R	0=INACTIVE, 1=ACTIVE	Phase A Frequency out of range

## BACnet Programming Information (cont.)

#	Name	Description	R/W	Range	Additional information
BI8	Reserved_BI8	Reserved	R	0=INACTIVE, 1=ACTIVE	Returns "INACTIVE"
BI9	Phase_Loss_A	Phase Loss Phase A	R	0=INACTIVE, 1=ACTIVE	Phase Loss - Phase A voltage dropped below the Phase Loss Threshold set by user
BI10	Phase_Loss_B	Phase Loss Phase B	R	0=INACTIVE, 1=ACTIVE	Phase Loss - Phase B voltage dropped below the Phase Loss Threshold set by user
BI11	Phase_Loss_C	Phase Loss Phase C	R	0=INACTIVE, 1=ACTIVE	Phase Loss - Phase C voltage dropped below the Phase Loss Threshold set by user
BI12	Power_Factor_A	Low Power Factor Phase A	R	0=INACTIVE, 1=ACTIVE	Phase A Power Factor less than 50% (commonly due to mis-wiring of CTs/PTs to meter)
BI13	Power_Factor_B	Low Power Factor Phase B	R	0=INACTIVE, 1=ACTIVE	Phase B Power Factor less than 50% (commonly due to mis-wiring of CTs/PTs to meter)
BI14	Power_Factor_C	Low Power Factor Phase C	R	0=INACTIVE, 1=ACTIVE	Phase C Power Factor less than 50% (commonly due to mis-wiring of CTs/PTs to meter)
BI15	RTC_Reset (E50H5 only)	RTC Reset	R	0=INACTIVE, 1=ACTIVE	Real-Time Clock reset. This goes active when the meter is powered after an interruption (since it does not use a battery backup). It indicates that the real-time clock has re-initialized to a default setting (00:00:00:00 on Jan 1, 2000) and should not be relied upon. The clock will run, the meter will operate and even log data (E50H5A only), but the date and time will not be correct until a Time_Synchronization occurs.

### Data Logging (E50H5A only)

The E50H5A includes a data logging feature that records three meter parameters, accessible via BACnet using Trend\_Log objects. All three Trend\_Log objects utilize shared data logging resources in the meter, so all three are controlled in unison. All writable properties other than Log\_Device\_Property\_Object are common to all three Trend\_Log objects. Changes to these properties (Log\_Enable, Start\_Time, Stop\_Time, Log\_Interval, Stop\_When\_Full or Record\_Count) for any one of the objects will be reflected in the corresponding property of all three objects. The Log\_Interval property is also common with the Demand\_Subinterval (Present\_Value of AV11), since logging records are updated synchronously with demand calculations.

Default settings cause logging to begin immediately, with 15 minute intervals and no stop time. When full, the buffer wraps and overwrites the oldest data first (unless the Stop\_When\_Full property is used).

#### Configuration:

Use Log\_Device\_Object\_Property to select the meter parameter to log with each object. Set this property to point to Present\_Value property of any of the Analog\_Input objects. The default the values for the Log\_Device\_Object\_Property of the three Trend\_Log objects are set as follows:

- TL1 = Real Energy Consumption (AI1 Present\_Value)
- TL2 = Reactive Energy Consumption (AI27 Present\_Value)
- TL3 = Total Real Power Present Demand (AI34 Present\_Value)

The Log\_Interval (& Demand Subinterval) can be set from 10 seconds to 32767 seconds (values of 1000 to 3276700). The subinterval timer, which determines how often the meter's demand accumulators are updated, also triggers writing to the Trend\_Log log buffers. Use the Log\_Interval property to set the data logging time subinterval, in units of hundredths of a second (0.01 seconds). The default subinterval is 15 minutes (a value of 90000 in the Log\_Interval property). The Buffer\_Length is fixed at 5760, so at a 15 minute interval setting, the buffers hold 60 days of data.

Use the Stop\_When\_Full property to select either Single Shot (Stop\_When\_Full = TRUE) or Continuous mode (Stop\_When\_Full = FALSE) for data logging. The default mode is Continuous. In Single Shot mode, the meter records data only until the buffer is full. Data for this time period is kept, but newer energy information is lost. In Continuous mode, the meter continues to record energy data as long as the meter is operating. The buffer can only hold 5760 entries at one time, however, so when the number of records exceeds 5760, the oldest entry is deleted to make room for the newest.

To start data logging with any of the three Trend\_Log objects, set the Log\_Enable property to TRUE or set the Start\_Time and Stop\_Time properties appropriately and wait for logging to commence at Start\_Time.

By default, the Record\_Count property of the Trend\_Log objects is initialized to Zero.

## BACnet Programming Information (cont.)

### Reading Data:

Access logged data with corresponding timestamps via the Log\_Buffer property of the Trend\_Log object using the BACnet ReadRange service. The E50H5A supports both the “by Position” and “by Sequence Number” modes of the ReadRange service, but not the “by Time” mode.

### Trend\_Log Objects

Trend_Log Properties Used	R/W	Units	Additional information
Object_Name	R	Trend_Log_<n>	Where n is 1-3 (there are three instances of Trend_Log objects available)
Description	R	Trend_Log <n>	Where n is 1-3 (there are three instances of Trend_Log objects available)
Log_Enable	W	Binary	Set this to TRUE to enable logging or FALSE to disable logging. The default is TRUE. The value is set to FALSE internally if logging stops for other reasons (i.e. buffer is full).
Start_Time	W	Date/Time	Sets the Date/Time when data logging starts (if Log_enable is TRUE). Set to a Date/Time earlier than the Local_Date/Local_Time properties of the Device object and Set Log_Enable TRUE to start logging immediately.
Stop_Time	W	Date/Time	Sets the Date/Time when data Logging stops (if still running). Stop_Time is ignored if “wildcard” values are used in any of the fields.
Log_Device_Object_Property	W	BACnetDeviceObjectPropertyReference	Set (point) this to the Present_Value of any of objects AI1 through AI49 to establish which parameter to log. Default values are: TL1 = Real Energy Consumption (Array of AI1 Present_Value) TL2 = Reactive Energy Consumption (Array of AI27 Present_Value) TL3 = Total Real Power Present Demand (Array of AI34 Present_Value)
Log_Interval	W	0.01 seconds	Logging period in hundredths of a second. Default is 90000 (15 minute intervals); minimum value is 1000 (10 seconds). This property can also be set to Zero, which will change all three Trend_Logs and the Demand calculation to a manual mode (sometimes referred to as “Sync to Comms”. In manual mode, the demand interval is updated and another record is logged upon a manual command, which is issued by writing the value 21211 to the Present_Value of object AV1.
Stop_When_Full	W	Binary	Set this to TRUE to stop logging when the buffer is full (single-shot mode) or FALSE to continue when full (wrap & overwrite oldest data entries).
Buffer_Size	R	5760	Length of Log Data buffer (# of records).
Log_Buffer	R	List of BACnetLongRecord	Contains the data values logged, with timestamps
Record_Count	W	Unsigned 32-bit integer	This is an integer count of how many records logged since the Trend_Log objects were last reset. Writing a Zero to this property resets the logs of all three objects. This value defaults to Zero, but, by default, logging starts automatically at 15 minute intervals.
Total_Record_Count	R	Unsigned 32-bit integer	This is an integer count of how many records logged since the Trend_Log objects were created (the factory state of the meter). This count is unaffected by resetting the Record Count or by power failures.
Event_State	R	Binary	

## Troubleshooting

Problem	Cause	Solution
The maintenance wrench icon appears in the power meter display.	There is a problem with the inputs to the power meter.	See the Alert sub-menu or the Diagnostic Alert Modbus Register 146
The display is blank after applying control power to the meter.	The meter is not receiving adequate power.	Verify that the meter control power are receiving the required voltage. Verify that the heart icon is blinking. Check the fuse.
The data displayed is inaccurate.	Incorrect setup values	Verify the values entered for power meter setup parameters (CT and PT ratings, system type, etc.). See the Setup section.
	Incorrect voltage inputs	Check power meter voltage input terminals to verify adequate voltage.
	Power meter is wired improperly.	Check all CTs and PTs to verify correct connection to the same service, PT polarity, and adequate powering. See the Wiring Diagrams section for more information.
Cannot communicate with power meter from a remote personal computer.	Power meter address is incorrect.	Verify that the meter is correctly addressed (see Setup section).
	Power meter baud rate is incorrect.	Verify that the baud rate of the meter matches that of all other devices on its communications link (see Setup section).
	Communications lines are improperly connected.	Verify the power meter communications connections (see the Communications section). Verify the terminating resistors are properly installed on both ends of a chain of units. Units in the middle of a chain should not have a terminator. Verify the shield ground is connected between all units.

## China RoHS Compliance Information (EFUP Table)

部件名称	产品中 有毒有害物质或元素的名称及含量 Substances					
	铅 (Pb)	汞 (Hg)	镉 (Cd)	六价铬 (Cr(VI))	多溴联苯 (PBB)	多溴二苯醚 (PBDE)
电子线路板	X	0	0	0	0	0
0 = 表示该有毒有害物质在该部件所有均质材料中的含量均在 SJ/T11363-2006 标准规定的限量要求以下。 X = 表示该有毒有害物质至少在该部件的某一均质材料中的含量超出SJ/T11363-2006标准规定的限量要求。						
Z000057-0A						